

# FP3 Valves

Air Pressure to Open / Spring to Close (failsafe)

*Part of the F Series of easily installed, compact, air intake valves for diesel engine emergency shut down.*



wyndham|page

## Application

The FP3 version of the Wyndham Page F Series of shutdown valves is designed to be installed in the air intake system of a diesel engine to provide an emergency means of rapid shutdown.

The FP3 valve is suitable for applications where there is a supply of filtered dry or lubricated air (or inert gas) available from 3 to 8 Bar (43 to 116 psi). This air supply is used to provide the continuous air pressure signal to hold the FP3 valve in the open state to enable the engine to be started and run. Loss of the air pressure signal at the FP3 valve results in the automatic closure of the valve thereby bringing the running engine to a stop within a few seconds. This failsafe mode of operation makes the FP3 valve suitable for application in hazardous areas as part of a full flame protection system.

A shutdown control system is required to automatically vent the air pressure signal to the FP3 when engine overspeed or any other selected fault condition, including loss of the supply air pressure, is sensed.

**Important Note:** A manual emergency shutdown button should also be incorporated in the shutdown control system. The control system should also be designed to require manual reset before the engine can be restarted following automatic or manual emergency shutdown. These two features are a mandatory requirement for some hazardous area applications.

The low intake air flow restriction through the open valve makes it generally compatible with the requirements of low emission diesel engines.

Corrosion resistant materials are used where applicable in the construction of the valve. This lightweight and compact valve design together with the availability of factory fitted hose adaptors selected from a wide range of optional sizes assists in easy installation.

The valve may be fitted to either turbocharged or naturally aspirated engines. In the case of turbocharged engines temperature limitations may restrict the position in which the valve may be installed in the intake system.

# Description and Main Dimensions

In standard form the FP3 valve is available complete with hose adaptors as selected by the customer from a range of standard sizes – see diagram below and data on pages 4 and 5. Where a requirement exists for a non-standard adaptor size or other alternative form of intake pipe connection such as bolted joint, please pass details of requirement to Wyndham Page or your Wyndham Page supplier for investigation.

The valve has a metal to metal seal when closed. It is designed for low closing friction and long life of the sealing surfaces and is designed to withstand high shock loads without malfunction.

The diagram below and the diagrams and data on pages 4 to 5 cover the main features and basic dimensions of the FP3 including selection of options and order coding.

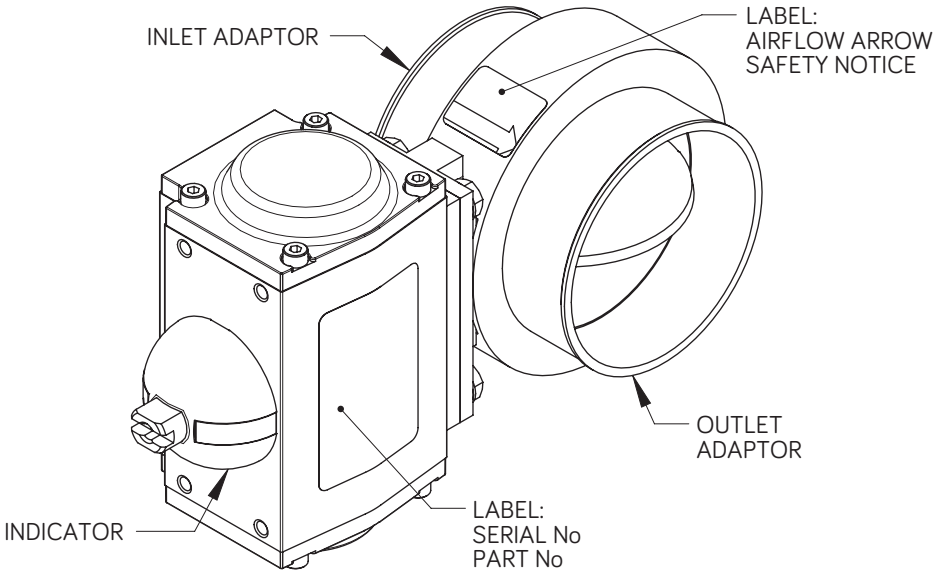

METRIC TABLE		DIMENSIONS (MM)					WEIGHT KG	ORDER CODE
MODEL	H TO SUIT HOSE BORE	BORE A	B	C	D	E		
FP3	38	57	81	196	50	20	1.38	38
	44						1.37	44
	51						1.38	51
	57						1.37	57
	64						1.37	64
	70						1.41	70
	76	71	99	215	28	25	1.22	76
	83						1.31	83
	89						1.51	89
	95						1.69	95
	102	95	125	241	35	25	1.68	102
	108						1.76	108
	114						1.85	114
	121						2.13	121
	127	120	154	270	42	25	2.14	127
	133						2.24	133
	140						2.37	140
	146						2.69	146
	152						2.94	152
	159						3.08	159
165	145	185	302	49	25	3.21	165	
171						3.35	171	
178						3.85	178	
203						5.36	203	

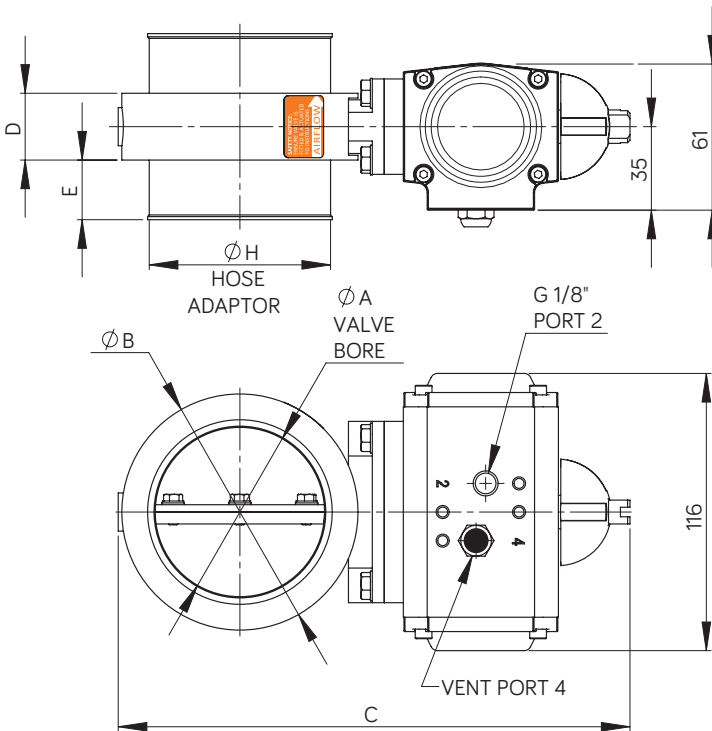

IMPERIAL TABLE		DIMENSIONS (INCHES)					WEIGHT LB	ORDER CODE
MODEL	H TO SUIT HOSE BORE	BORE A	B	C	D	E		
FP3	1.50	2.24	3.19	7.72	1.97	0.79	3.04	38
	1.73						3.02	44
	2.01						3.04	51
	2.24						3.02	57
	2.52						3.02	64
	2.76						3.11	70
	2.99	2.80	3.90	8.46	1.10	0.98	2.69	76
	3.27						2.89	83
	3.50						3.33	89
	3.74						3.73	95
	4.02	3.74	4.92	9.49	1.38	0.98	3.70	102
	4.25						3.88	108
	4.49						4.08	114
	4.76						4.70	121
	5.00	4.72	6.06	10.63	1.65	0.98	4.72	127
	5.24						4.94	133
	5.51						5.23	140
	5.75						5.93	146
	5.98	5.69	7.25	11.84	1.92	0.98	6.48	152
	6.26						6.79	159
6.50	7.08						165	
6.73	7.39						171	
7.01	8.49						178	
7.99	7.56						9.37	13.82

## Valve Selection

To enable Wyndham Page to select the most suitable version of the FP3 valve for the Customers application the following data is required:

Bore size of the intake hose into which the intake valve is to be fitted - refer to section headed "Description and Main Dimensions".

## Order Coding

**FP3 - XXX - S000**

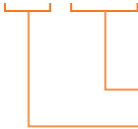

**Special features code** (refer to sales)

**Adaptor size** (order code in table)

### Special Features:

By arrangement with Wyndham Page.

## Installation

Select a position for the valve which meets the requirements below and also permits a suitable run for the pneumatic pipework. Ensure direction of the engine intake airflow complies with that marked on the valve.

The valve may be fitted in any attitude from horizontal to vertical but not in a position where it is subjected to temperatures, internal or external, outside of the range -40C to +120C. The maximum pressure of the pneumatic signal applied to the FP3 valve is not to exceed 8 Bar (116 psi).

If an engine air intake flametrap is also fitted, the valve must be installed upstream (air cleaner side) of the flametrap.

Additionally in the case of naturally aspirated engines fit the valve as close as possible to the intake manifold.

For turbocharged engines fit the valve upstream of the turbocharger except where a charge cooler is fitted in which case it may be fitted downstream of the charge cooler subject to not exceeding the +120C limit.

**Do not** fit valve between the turbocharger and charge cooler.

The hose and associated intake system into which the valve is installed should be adequate to fully support the valve whilst not permitting excessive vibration of the valve. Generally ensure that there is sufficient flexibility in the finalised intake system to allow for the necessary relative movement between the intake system components over the full range of engine operating conditions to avoid excessive mechanical stresses. Ensure the quality and length of the sections of flexible intake pipe are such that when the intake valve closes with the engine at full rating hose collapse is avoided.

In the case of an engine with multiple air intake systems requiring the fitting of more than one FP3 valve, a common pneumatic supply must be used for valve actuation to ensure all intake shutdown valves operate simultaneously.

Any existing crankcase breather arrangement venting directly into the engine intake ports or into the intake system downstream of the FP3 valve, must be sealed and replaced by a crankcase breather arrangement connected into the intake system upstream of the FP3 valve or, if permitted at the operating site, vented to atmosphere.

The pneumatic pipework must be adequately secured along its length to avoid excessive mechanical stress at the connection to the actuator or any other physical damage under all normal operating conditions and during equipment servicing.

**Important note.** Retain the standard fuel shutdown stop fitted to the engine. The Wyndham Page FP3 air intake valve is designed for emergency stop only.

# General and Pneumatic Specification

GENERAL DESCRIPTION:	
A slim butterfly valve designed for emergency shut off of the engine air intake.	
Operating Mode: Air pressure to open, Spring to close (failsafe).	
GENERAL SPECIFICATION:	
Temperature:	Ambient: -40°C to 120°C Max intake air temp: 120°C
Construction:	Body and disk: Hard anodized Aluminium Other main components: Stainless steel, Aluminium Hose adaptors: Aluminium
PNEUMATIC ACTUATOR SPECIFICATION:	
Air Pressure:	Min: 3 Bar (43 psi) Max: 8 Bar (116 psi)
Air Supply:	Filtered Air: ISO 8573 Class 4

## Operation

Complete all routine pre-start checks.

Turn on / reset the shutdown control system to supply air pressure to open the FP3 valve prior to engine start. Note, the air signal pressure at the valve must be continually maintained between 3 and 8 Bar (43 and 116 psi) to hold the FP3 valve fully open. Should the supply pressure fall below approximately 1 Bar (14 psi) the valve will fully close thereby stopping the engine.

Normal engine shutdown should always be via the standard fuel shutdown.

Should the engine standard fuel shutdown fail to stop the engine, operate the manual emergency stop in the shutdown control system to vent the air pressure supply to the FP3.

The FP3 valve has no automatic reset function. It can only be operated by the application or removal of the control air pressure signal within the specified limits.



## Maintenance

The following maintenance schedule should be undertaken. Subject to experience of local operating conditions the frequency of the maintenance schedule may be varied. Carry out the proposed maintenance work when the equipment is in a safe area and record details of the work carried out. Rectify any problems identified before returning the diesel powered equipment back into service.

### FOLLOWING INITIAL INSTALLATION AND THEREAFTER AT WEEKLY INTERVALS:

- [1]. Check all intake pipework between the FP3 valve and engine intake manifold to ensure all pipe fittings and any support brackets are properly fitted and secure and that the engine intake is leak free and shows no sign of significant deterioration or damage.
- [2]. Check out all pipework associated with the shutdown control system for freedom from damage and to ensure all pipe supports are secured and all pipe fittings tight and leak free.
- [3]. Apply the air pressure shutdown control signal to the valve. Check that the valve moves smoothly and quickly from closed to open status. [Note the valve position indicator on the actuator mounted on the valve will confirm valve status].
- [4]. Start engine. Carry out a shutdown using the stop signal from the shutdown control system. Check that the valve snaps shut and brings the engine to a stop within a few seconds.

### SIX MONTHLY:

Remove the FP3 valve. Wipe clean as necessary and visually inspect for damage or excessive wear. Bench test valve function. Refit and complete the “Weekly” maintenance as listed above.

wyndham | page

Unit 1c Chalwyn Industrial Estate, Parkstone, Poole,  
Dorset BH12 4PE United Kingdom

Tel: +44 (0)1202 734 656

Email: [sales@wyndhampage.com](mailto:sales@wyndhampage.com)

[www.wyndhampage.com](http://www.wyndhampage.com)