

FS1 Valves

Solenoid Powered to Close / Manual Reset Butterfly Valves

Part of the F Series of easily installed, compact, air intake valves for diesel engine emergency shut down.

New Speed Switch Kit
available for a complete
overspeed installation

See page 2



wyndham|page

Application

The FS1 version of the Wyndham Page F Series of engine air intake closure valves is designed to provide an emergency means for rapid shutdown of a diesel engine when triggered by a 12 or 24 Volt DC signal. This signal may be generated automatically by engine overspeed or any other selected fault condition or via a manually operated electrical engine stop button. Optionally for additional safety the valve can also be supplied with a mechanical emergency engine stop button either directly mounted on the valve or remotely mounted for operation via a mechanical cable.

Once the FS1 valve has operated to stop the engine, a restart is only possible after manually resetting the valve to the run position.

The low intake airflow restriction through the open valve makes it generally compatible with the requirements of low emission diesel engines.

Corrosion resistant materials are used where applicable in the construction of the valve. This lightweight and compact valve design together with the availability of factory fitted hose adaptors selected from a wide range of optional sizes assists in easy installation.

The valve may be fitted to either turbocharged or naturally aspirated engines. In the case of turbocharged engines temperature limitations may restrict the position in which the valve may be installed in the intake system.

New Speed Switch Kits now available

Wyndham Page also supplies Speed Switches and a range of Installation Kits for incorporation into the emergency shutdown control circuit of this type of application. Details can be found in our **“FS1 Valve - Electrical Installation Kits Handbook”** available for download on our website. Please contact Wyndham Page or your Wyndham Page supplier for additional details.

Note. The FS1 valve needs to have a M3 microswitch configuration to use with our kit.

Description and Main Dimensions

The FS1 butterfly valve is a latched open type. Either operation of the manual engine shutdown button [where fitted] or applying a 12 or 24 volt DC signal is required to trip the valve to the closed [engine stop] position. Following valve closure the manual reset lever on the valve is used to reset to the latched open position. Optionally the valve can be supplied with a cable and lever arrangement to permit manual reset from a position remote from the engine.

In standard form the FS1 valve is available complete with integrated hose adaptors as selected by the Customer from a range of standard sizes – see diagram below and data on pages 4 and 5. Where a requirement exists for a non-standard adaptor size or other alternative form of pipe connection such as a bolted joint please pass details of your requirement to Wyndham Page or your Wyndham Page supplier for investigation.

The valve is supplied fitted as standard with an internal microswitch to indicate the open/closed status of the valve. For details on the microswitch options see pages 6 and 7.

The valve has a metal to metal seal when closed. It is designed for low closing friction and long life of the sealing surfaces. The latching / release mechanism is configured to withstand high shock loads without malfunction.

The electrical enclosure is to IP66.

The diagram below and the diagrams and data on pages 4 to 8 cover the main features and basic dimensions of the FS1 range including selection of options and order coding.

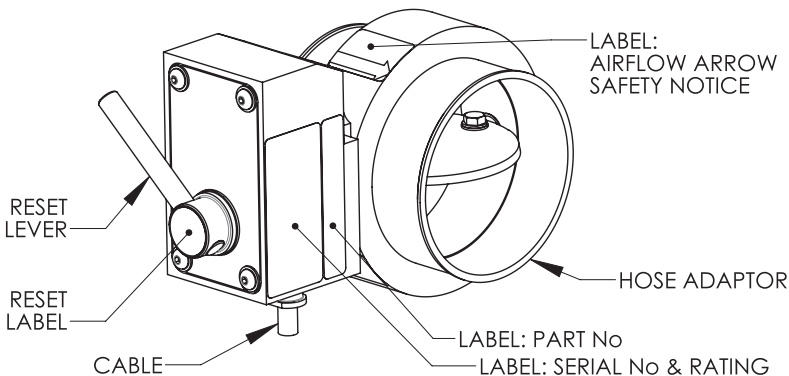

METRIC TABLE		DIMENSIONS (MM)					WEIGHT KG	ORDER CODE
MODEL	H TO SUIT HOSE BORE	BORE A	B	C	D	E		
FS1	38	57	81	136	50	20	1.08	038
	44						1.08	044
	51						1.08	051
	57						1.07	057
	64						1.08	064
	70						1.11	070
	70	65	91	146	28	25	0.97	070S
	76	71	99	154	28	25	1.05	076
	83						1.14	083
	89						1.21	089
	95						1.28	095
	102	95	125	180	35	25	1.38	102
	108						1.46	108
	114						1.55	114
	121						1.66	121
	127						1.84	127
	133						1.95	133
	140	120	154	209	42	25	2.07	140
	146	145	185	241	49	25	2.19	146
	152						2.64	152
159	2.79						159	
165	2.92						165	
171	3.05						171	
178	3.22						178	

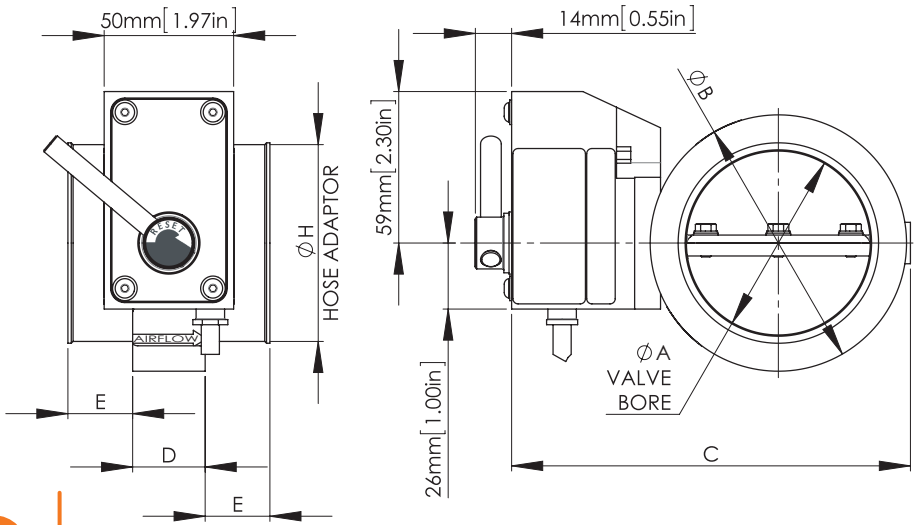

IMPERIAL TABLE		DIMENSIONS (INCHES)					WEIGHT LB	ORDER CODE
MODEL	H TO SUIT HOSE BORE	BORE A	B	C	D	E		
FS1	1.50	2.2	3.18	5.33	1.97	0.79	2.38	038
	1.73						2.38	044
	2.01						2.38	051
	2.24						2.36	057
	2.52						2.38	064
	2.76						2.45	070
	2.76	2.56	3.58	5.75	1.10	0.98	2.14	070S
	2.99	2.80	3.90	6.06	1.10	0.98	2.32	076
	3.27						2.51	083
	3.50						2.67	089
	3.74						2.82	095
	4.02	3.74	4.92	7.09	1.38	0.98	3.04	102
	4.25						3.22	108
	4.49						3.42	114
	4.76						3.66	121
	5.00						4.06	127
	5.24	4.72	6.06	8.23	1.65	0.98	4.30	133
	5.51						4.56	140
	5.75						4.83	146
	5.98						5.82	152
6.26	5.71	7.28	9.49	1.93	0.98	6.15	159	
6.50						6.44	165	
6.73						6.73	171	
7.01						7.10	178	

Valve Selection

To enable Wyndham Page to select the most suitable version of the FS1 valve for the Customers application the following data is required:

- [1]. Bore size of the intake hose into which the intake valve is to be fitted - refer to section headed "Installation [mechanical]".
- [2]. Whether a 12 volt or 24 volt DC shutdown signal is to be used.
- [3]. The microswitch operating mode - see schematics on pages 6 and 7.
- [4]. If a remote manual reset required, select suitable cable length - see range on page 6.
- [5]. If a remote mechanical engine stop button is required, select cable length - see range on page 6.

Order Coding

FS1 - XXX - XX - MX - RXX - EXX - S00

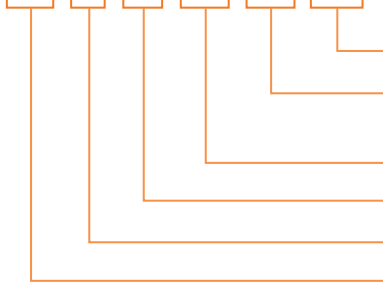

- Special features code** (refer to sales)
- Manual stop option:** E or EXX for cable length (see table below)
- Reset cable option:** Length RXX (see table below)
- Microswitch option:** M1, M2 or M3
- Voltage:** 12 or 24 VDC
- Adaptor size** (order code in table)

STANDARD CABLE LENGTHS	
CABLE XX CODE	LENGTH (M)
05	0.5
10	1.0
15	1.5
20	2.0
25	2.5
30	3.0

Special Features:
By arrangement with Wyndham Page.

Microswitch Options

Microswitch option M1

Suitable for customers controlling the valve via their own electrical systems.

FS1 - M1 Valve:

Internal wiring schematic

Not applicable to the FS1-203

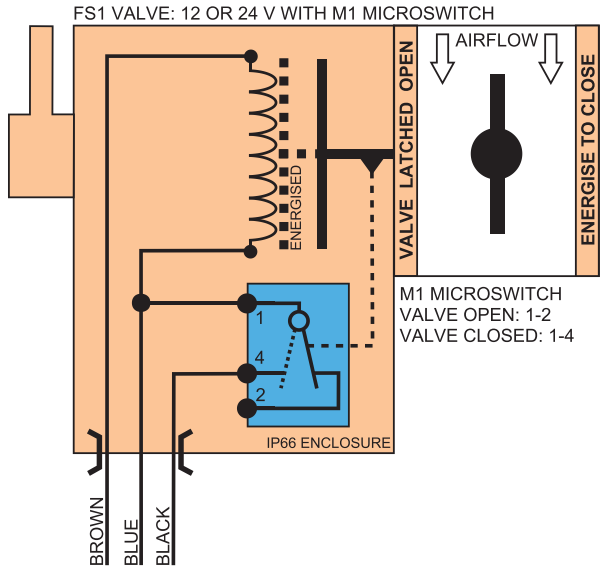

Microswitch option M2

Suitable for customers controlling the valve via their own electrical systems.

FS1 - M2 Valve:

Internal wiring schematic

Not applicable to the FS1-203

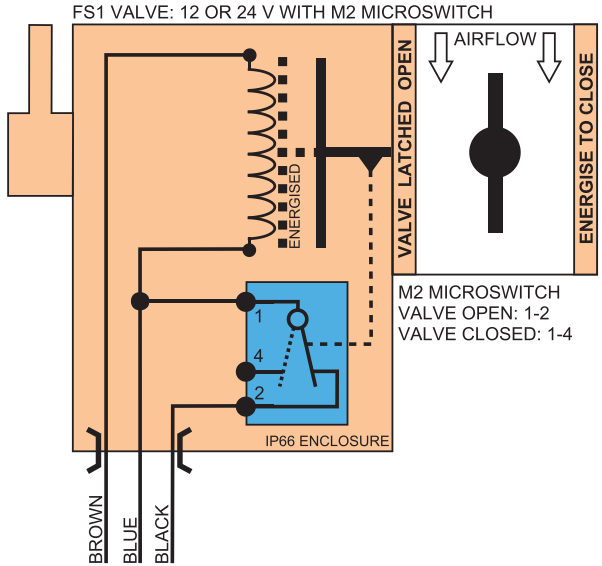

Microswitch option M3

Provides inbuilt protection for the solenoid which is wired through the microswitch. Designed for use with the Wyndham Page FK-S1 range of installation kits.

FS1 - M3 Valve:

Internal wiring schematic

Not applicable to the FS1-203

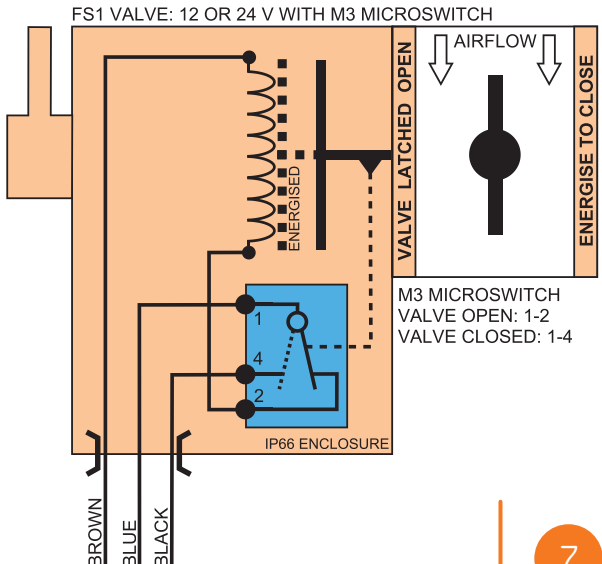

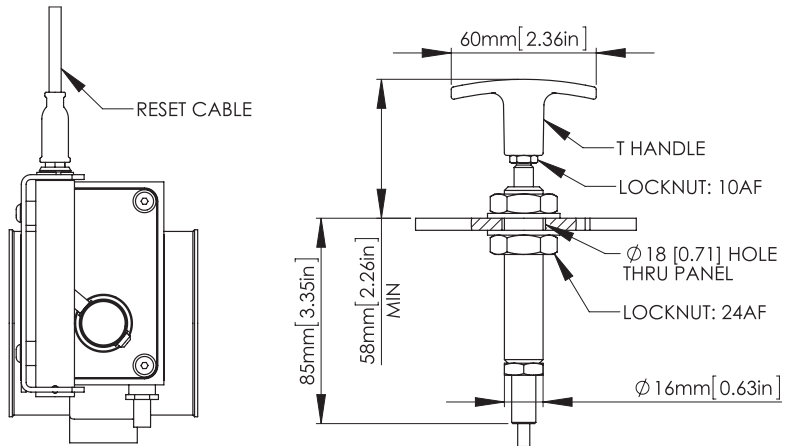

RESET CABLE OPTION: ORDER CODE RXX

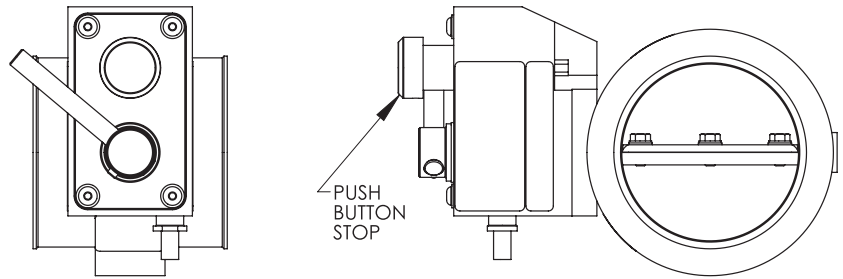

PUSH BUTTON MANUAL STOP OPTION: ORDER CODE E

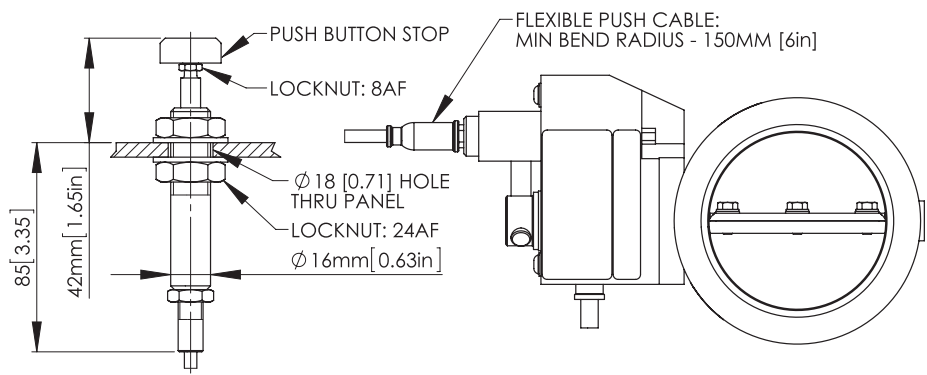

REMOTE PUSH BUTTON MANUAL STOP OPTION: ORDER CODE EXX

Installation [mechanical]

Select a position for the valve which enables safe access to operate the reset lever and also permits a suitable run for the connected electrical cables and, when applicable, mechanical manual stop and / or reset cables. Ensure that the direction of the engine intake airflow complies with that marked on the valve. If an engine air intake system flametrap is also fitted, the shut down valve must be installed upstream (air cleaner side) of the flametrap.

The valve may be fitted in any attitude from horizontal to vertical but not in a position where it is subjected to temperatures, internal or external, outside of the range -40°C to $+120^{\circ}\text{C}$.

Additionally in the case of naturally aspirated engines fit the valve as close as possible to the intake manifold.

For turbocharged engines fit the valve upstream of the turbocharger except where a charge cooler is fitted in which case it may be fitted downstream of the charge cooler subject to not exceeding the $+120^{\circ}\text{C}$ limit. **Do not** fit the valve between the turbocharger and charge cooler.

The valve must always be fitted downstream of an engine air filter.

When installing valves fitted with the Reset Cable RXX option ensure that the bend radius of the Reset Cable does not restrict the reset mechanism from pulling the T Handle back into the run position. If it is found that the T Handle is not being pulled fully in then a straighter run for the reset cable must be used.

The hose and associated intake system into which the valve is installed should be adequate to fully support the valve whilst not permitting excessive vibration of the valve. Generally ensure that there is sufficient flexibility in the finalised intake system to allow for the necessary relative movement between the intake system components over the full range of engine operating conditions to avoid excessive mechanical stresses.

Any existing crankcase breather arrangement venting directly into the engine intake ports or into the intake system downstream of the FS1 valve, must be sealed and replaced by a crankcase breather arrangement connected into the intake system upstream of the FS1 valve or, if permitted at the operating site, vented to atmosphere.

Important note. Retain the standard fuel shut down stop fitted to the engine. The Wyndham Page FS1 air intake valve is designed for emergency stop only.

Installation [electrical]

The wiring diagrams on pages 6 and 7 show the connections for the valve solenoid and microswitch.

The electrical data for the solenoid and microswitch is tabulated on page 11.

It is recommended that either a manually operated electrical engine stop button or a remotely operated mechanical engine stop button is always incorporated.

Important notes.

- [1]. The electrical system must include means to restrict the maximum time the closure signal may be applied to the solenoid to within the limits stated on page 11. This restriction must also be applied where a manually operated electrical engine stop button is also incorporated in the electrical shutdown circuit.
- [2]. It is recommended that for additional safety when a manually operated electrical engine stop button is incorporated it should be directly supplied by the required voltage from source and not via the shutdown control circuit.

General and Electrical Specification

GENERAL DESCRIPTION:	
A slim butterfly valve designed for emergency shutoff of the engine air intake.	
Mechanically latched open, energise to close, manual reset by rotation of reset knob.	
GENERAL SPECIFICATION:	
Temperature:	Max ambient: 120°C Max intake air temp: 120°C
Construction:	Body and disk: Hard anodized aluminium Other main components: Stainless steel, aluminium Hose adaptors: Aluminium
ELECTRICAL SPECIFICATION:	
Solenoid energise to close operation	
12 or 24 volt option specified when ordering	
Solenoid rating:	12 Volt, 7.5A, 90W 24 Volt, 3.75A, 90W Solenoid rating 10%
Max single pulse @20°C:	8 seconds
Max on time in 1 minute @20°C:	6 seconds
Recommended engine controller setting:	1 second
MICROSWITCH:	
S.P.S.T - 24V, 10A Max	
Code M1: Switch open when valve in open position	
Code M2: Switch closed when valve in open position	
Code M3: Refer to schematic on page 7	
CABLE:	
SIHF silicone insulated multicore cable: Standard length 3m	

Operation

The valve closure disc is sprung towards the engine stop [closed] position. It is latched in the engine run [open] position by rotating the reset latch as indicated on the valve body, or, where a remote manual reset is fitted, by pulling the reset 'T' handle. During engine operation the valve remains open until the 12 or 24 volt DC shutdown signal is applied or the manual emergency stop button is operated. This releases the valve disc from the run position to the stop position thereby shutting down the engine.

Note. Unless released to the closed position by an electrical signal or the manual emergency stop button the valve disc will continue to remain in the latched open state and therefore following a normal engine stop by fuel shut down it will not require reset.

The valves internal microswitch permits an indication of the valves open / closed status.

Maintenance

The following maintenance schedule should be undertaken. Subject to experience of local operating conditions the frequency of the maintenance schedule may be varied. Carry out the proposed maintenance work when the equipment is in a safe area and record details of the work carried out. Rectify any problems identified before returning the diesel powered equipment back into service.

FOLLOWING INITIAL INSTALLATION AND THEREAFTER AT WEEKLY INTERVALS:

- [1]. Check all intake pipework between the FS1 valve and engine intake manifold to ensure all pipe fittings and any support brackets are properly fitted and secure and that the engine intake is leak free and shows no sign of significant deterioration or damage.
- [2]. Where the valve has been fitted with a Reset Cable RXX option inspect and if required clean off any contamination from the reset lever, reset mechanism slide and T Handle shaft and spray with a suitable light cleaner/lubricant. Check that the Reset mechanism pulls the T Handle fully back into the run position.
- [3]. Start engine. Carry out a shut down using the stop signal from the shut down control system. Check that the valve snaps shut and brings the engine to a stop within a few seconds.

SIX MONTHLY:

Remove the FS1 valve. Wipe clean as necessary and visually inspect for damage or excessive wear. Bench test valve function. Refit and complete the “Weekly” maintenance as listed above.

Notes:

Notes:

wyndham | page

Unit 1c Chalwyn Industrial Estate, Parkstone, Poole,
Dorset BH12 4PE United Kingdom

Tel: +44 (0)1202 734 656

Email: sales@wyndhampage.com

www.wyndhampage.com