

FS2 Valves

Solenoid Powered to Close / Auto Reset Butterfly Valves

Part of the F Series of easily installed, compact, air intake valves for diesel engine emergency shut down.



wyndham|page

Application

The FS2 version of the Wyndham Page F Series of engine air intake closure valves is designed to be installed in the air intake system of a diesel engine to provide an emergency means of rapid shut down when triggered by a 12 or 24 volt signal. This signal may be generated automatically by engine overspeed or any other selected fault conditions and /or applied via a manual emergency stop button.

Once the FS2 valve has operated to stop the engine the valve will automatically reset to the open [engine run] state as soon as the shut down signal is no longer applied.

The low intake air flow restriction through the open valve makes it generally compatible with the requirements of low emission diesel engines.

Corrosion resistant materials are used where applicable in the construction of the valve. This lightweight and compact valve design together with the availability of factory fitted hose adaptors selected from a wide range of optional sizes assists in easy installation.

The valve may be fitted to either turbocharged or naturally aspirated engines. In the case of turbocharged engines temperature limitations may restrict the position in which the valve may be installed in the intake system.

Note. Wyndham Page also supply speed switches for incorporation into the emergency shut down control circuit of this type of application. Please contact Wyndham Page or your Wyndham Page supplier for details.

Description and Main Dimensions

Versions of the FS2 valve can be selected to operate by either a 12 volt or 24 volt shut down signal. Once the input shut down signal is removed the valve always automatically resets to the open status.

In standard form the FS2 valve is available complete with formed hose adaptors as selected by the customer from a range of standard sizes – see diagram below and data on pages 4 and 5. Where a requirement exists for a non-standard adaptor size or other alternative form of intake pipe connection such as bolted joint, please pass details of requirement to Wyndham Page or your Wyndham Page supplier for investigation.

Optionally the valve can be supplied fitted with an internal microswitch to indicate the open / closed status of the valve.

The valve has a metal to metal seal when closed. It is designed for low closing friction and long life of the sealing surfaces. The latching / release mechanism is configured to withstand high shock loads without malfunction.

The electrical enclosure is to IP66.

The diagram below and the diagrams and data on pages 4 to 6 cover the main features and basic dimensions of the FS2 range including selection of options and order coding.

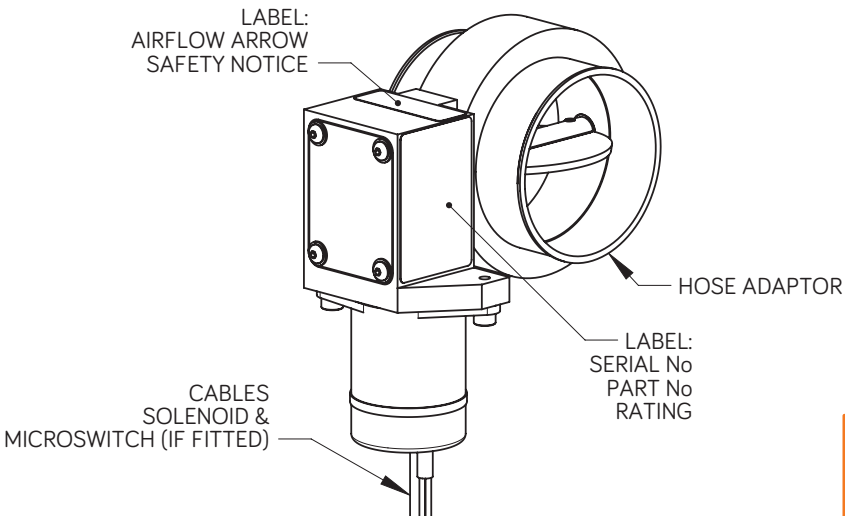

| METRIC TABLE | | DIMENSIONS (MM) | | | | | WEIGHT KG | ORDER CODE |
|--------------|---------------------------|-----------------|-----|-----|----|------|--------------|---------------|
| MODEL | H TO SUIT HOSE BORE | BORE A | B | C | D | E | | |
| FS2 | 38 | 57 | 81 | 131 | 50 | 20 | 1.47 | 038 |
| | 44 | | | | | | 1.47 | 044 |
| | 51 | | | | | | 1.47 | 051 |
| | 57 | | | | | | 1.46 | 057 |
| | 64 | | | | | | 1.46 | 064 |
| | 70 | 1.51 | 070 | | | | | |
| | 76 | 1.44 | 076 | | | | | |
| | 83 | 71 | 99 | 149 | 28 | 25 | 1.53 | 083 |
| | 89 | | | | | | 1.60 | 089 |
| | 95 | | | | | | 1.68 | 095 |
| | 102 | 95 | 125 | 175 | 35 | 25 | 1.77 | 102 |
| | 108 | | | | | | 1.85 | 108 |
| | 114 | | | | | | 1.94 | 114 |
| | 121 | | | | | | 2.05 | 121 |
| | 127 | | | | | | 2.24 | 127 |
| | 133 | 120 | 154 | 204 | 42 | 25 | 2.34 | 133 |
| | 140 | | | | | | 2.47 | 140 |
| | 146 | | | | | | 2.58 | 146 |
| | 152 | 145 | 185 | 236 | 49 | 25 | 3.04 | 152 |
| | 159 | | | | | | 3.18 | 159 |
| 165 | 3.30 | | | | | | 165 | |
| 171 | 3.44 | | | | | | 171 | |
| 178 | 3.61 | | | | | | 178 | |
| 203 | 192 | 238 | 291 | 65 | 40 | 5.69 | 203 | |

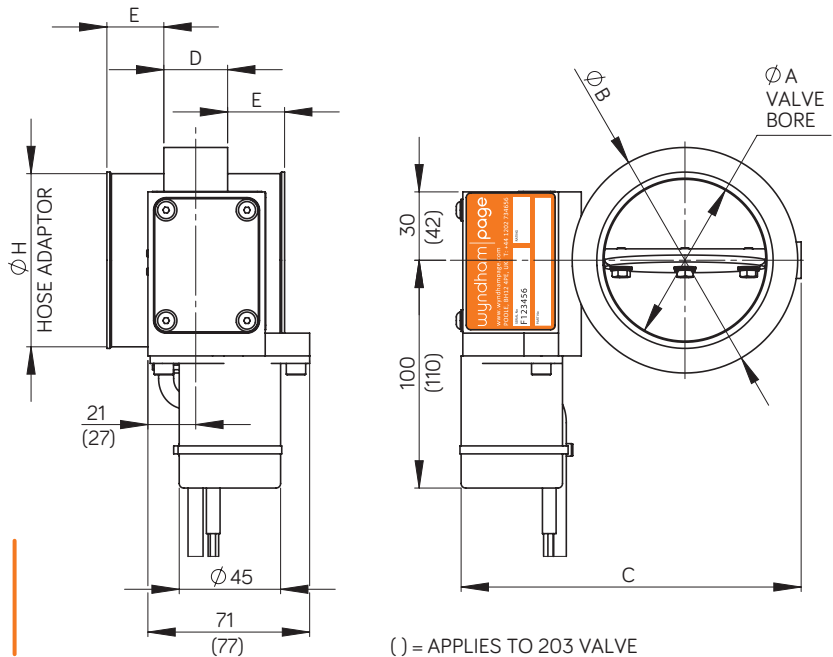

() = APPLIES TO 203 VALVE

| IMPERIAL TABLE | | DIMENSIONS (INCHES) | | | | | WEIGHT LB | ORDER CODE | | | | |
|----------------|---------------------------|---------------------|------|------|------|------|--------------|---------------|------|------|-------|-----|
| MODEL | H TO SUIT HOSE BORE | BORE A | B | C | D | E | | | | | | |
| FS2 | 1.50 | 2.2 | 3.18 | 5.14 | 1.97 | 0.79 | 3.24 | 038 | | | | |
| | 1.73 | | | | | | 3.24 | 044 | | | | |
| | 2.01 | | | | | | 3.24 | 051 | | | | |
| | 2.24 | | | | | | 3.22 | 057 | | | | |
| | 2.52 | | | | | | 3.22 | 064 | | | | |
| | 2.76 | 2.80 | 3.90 | 5.87 | 1.10 | 0.98 | 3.33 | 070 | | | | |
| | 2.99 | | | | | | 3.18 | 076 | | | | |
| | 3.27 | | | | | | 3.37 | 083 | | | | |
| | 3.50 | | | | | | 3.53 | 089 | | | | |
| | 3.74 | | | | | | 3.70 | 095 | | | | |
| | 4.02 | 3.74 | 4.92 | 6.89 | 1.38 | 0.98 | 3.90 | 102 | | | | |
| | 4.25 | | | | | | 4.08 | 108 | | | | |
| | 4.49 | | | | | | 4.28 | 114 | | | | |
| | 4.76 | | | | | | 4.52 | 121 | | | | |
| | 5.00 | | | | | | 4.94 | 127 | | | | |
| | 5.24 | 4.72 | 6.06 | 8.03 | 1.65 | 0.98 | 5.16 | 133 | | | | |
| | 5.51 | | | | | | 5.45 | 140 | | | | |
| | 5.75 | | | | | | 5.69 | 146 | | | | |
| | 5.98 | | | | | | 6.70 | 152 | | | | |
| | 6.26 | | | | | | 7.01 | 159 | | | | |
| 6.50 | 5.71 | 7.28 | 9.29 | 1.93 | 0.98 | 7.28 | 165 | | | | | |
| 6.73 | | | | | | 7.59 | 171 | | | | | |
| 7.01 | | | | | | 7.96 | 178 | | | | | |
| 7.99 | | | | | | 7.56 | 9.37 | 11.46 | 2.56 | 1.57 | 12.55 | 203 |

Valve Selection

To enable Wyndham Page to select the most suitable version of the FS2 valve for the Customers application the following data is required:

- [1]. Bore size of the intake hose into which the intake valve is to be fitted - refer to section headed "Installation [mechanical]".
- [2]. Whether a 12 volt or 24 volt shut down signal is to be used.
- [3]. Whether a built in microswitch is required.

Order Coding

FS2 - XXX - XX - M - S000

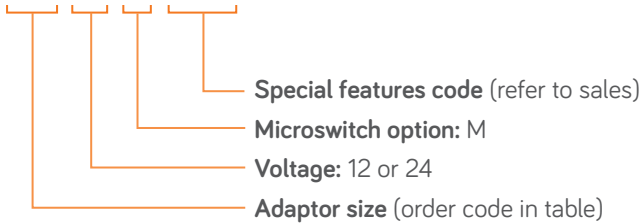

Special Features:

By arrangement with Wyndham Page.

Installation [mechanical]

Select a position for the valve which meets the requirements below and also permits a suitable run for the connected electrical cables. Ensure direction of the engine intake airflow complies with that marked on the valve. If an engine air intake system flametrap is also fitted, the shut down valve must be installed upstream (air cleaner side) of the flametrap.

The valve may be fitted in any attitude from horizontal to vertical but not in a position where it is subjected to temperatures, internal or external, outside of the range -40C to +120C.

Additionally in the case of naturally aspirated engines fit the valve as close as possible to the intake manifold.

For turbocharged engines fit the valve upstream of the turbocharger except where an air charge cooler is fitted in which case it may be fitted downstream of the charge cooler subject to not exceeding the +120C limit. **Do not** fit valve between the turbocharger and charge cooler.

The hose and associated intake system into which the valve is installed should be adequate to fully support the valve whilst not permitting excessive vibration of the valve. Generally ensure that there is sufficient flexibility in the finalised intake system to allow for the necessary relative movement between the intake system components over the full range of engine operating conditions to avoid excessive mechanical stresses.

Any existing crankcase breather arrangement venting directly into the engine intake ports or into the intake system downstream of the FS2 valve, must be sealed and replaced by a crankcase breather arrangement connected into the intake system upstream of the FS2 valve or, if permitted at the operating site, vented to atmosphere.

Important Note. Retain the standard fuel shut down stop fitted to the engine. The Wyndham Page FS2 air intake valve is designed for emergency stop only.

Installation [electrical]

The wiring diagrams show the connections for the valve solenoid and, where applicable, the optional microswitch.

The electrical data for the solenoid and microswitch is tabulated on page 9.

It is recommended that a manual switch for emergency stop is always incorporated.

Important notes.

- [1]. Design of the electrical shut down system must take into account the limitations applicable in terms of applying power to the solenoid [see solenoid electrical specification on page 9]. This restriction must also be applied where a manual shut down switch is also incorporated in the electrical shut down circuit.
- [2]. It is recommended that for additional safety when a manual shut down switch is incorporated it should be directly supplied at the correct voltage from source and not via the shut down control circuit.

FS2 VALVE SCHEMATIC:

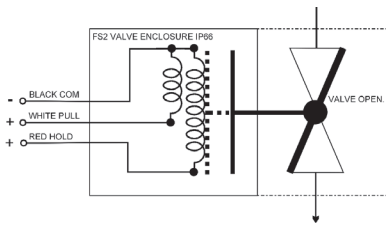

FS2 VALVE SCHEMATIC: Microswitch Version

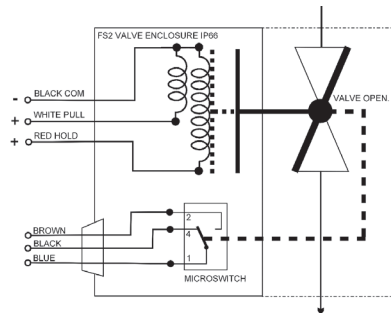

General and Electrical Specification

| | |
|---|---|
| GENERAL DESCRIPTION: | |
| A slim butterfly valve designed for emergency shutoff of the engine air intake. | |
| Operating mode: Spring open, energise to close. | |
| Duel coil solenoid. | |
| GENERAL SPECIFICATION: | |
| Temperature: | Max ambient: 120°C Max intake air temp: 120°C |
| Construction: | Body and disk: Hard anodized aluminium Other main components: Stainless steel, aluminium Hose adaptors: Aluminium |
| ELECTRICAL SPECIFICATION: | |
| Energise pull coil to close, energise hold coil to hold valve in closed position after engine stop if required. | |
| 12 or 24 volt option specified when ordering | |
| Solenoid rating: | 12 Volt: Pull Coil - 46A, Hold Coil - 1.1A 24 Volt: Pull Coil - 25A, Hold Coil - 0.5A |
| Pull coil max single pulse: | 1.5 seconds |
| Max 4 cycles in one minute | |
| Recommended engine controller setting: | 1 second pull |
| MICROSWITCH OPTION: | |
| S.P.D.T - 24V, 10A Max | |
| MICROSWITCH CABLE: | |
| SIHF silicone insulated multicore cable: Standard length 3m | |

Operation

The FS2 valve is always held in the open [engine run] state except whilst a shut down signal at the specified voltage is applied. This signal causes the solenoid within the valve to rotate the valve disc from the run position to the stop position thereby shutting down the engine.

The FS2 valve has no manual reset facility. It can only be operated by the application or removal of an electrical signal at the appropriate voltage.

Where fitted the valves internal microswitch permits an indication of the valves open / closed status.

Maintenance

The following maintenance schedule should be undertaken. Subject to experience of local operating conditions the frequency of the maintenance schedule may be varied. Carry out the proposed maintenance work when the equipment is in a safe area and record details of the work carried out. Rectify any problems identified before returning the diesel powered equipment back into service.

FOLLOWING INITIAL INSTALLATION AND THEREAFTER AT WEEKLY INTERVALS:

- [1]. Check all intake pipework between the FS2 valve and engine intake manifold to ensure all pipe fittings and any support brackets are properly fitted and secure and that the engine intake is leak free and shows no sign of significant deterioration or damage.
- [2]. Start engine. Carry out a shut down using the stop signal from the shut down control system. Check that the valve snaps shut and brings the engine to a stop within a few seconds.

SIX MONTHLY:

Remove the FS2 valve. Wipe clean as necessary and visually inspect for damage or excessive wear. Bench test valve function. Refit and complete the “Weekly” maintenance as listed above.

wyndham | page

Unit 1c Chalwyn Industrial Estate, Parkstone, Poole,
Dorset BH12 4PE United Kingdom

Tel: +44 (0)1202 734 656

Email: sales@wyndhampage.com

www.wyndhampage.com