

# ET Valves

Combined Manual and Automatic Engine Overspeed  
Shut Down Valves with Integrated Flametrap Housing

*A range of easily installed diesel engine air intake valves which combine automatic closure on engine overspeed with oil or air pressure actuated closure and manual emergency closure.*



wyndham|page

## Application

The Wyndham Page ET series of combined manual and automatic overspeed shutdown valves are designed for situations where flammable gas or vapour may enter the atmosphere in an area in which a diesel engine is operating.

Should such flammable material be drawn into the engine intake this may result in uncontrolled engine overspeed and a situation in which shutdown of the normal diesel fuel supply may fail to stop the engine.

Under these circumstances a rapid shutdown of the engine is required by immediate closure of the engine air intake thereby reducing the potential for major damage and possible ignition of the flammable material in the surrounding atmosphere.

For additional safety the ET Series valve also includes automatic air intake shutdown on detection of low engine oil pressure. This additional automatic shutdown arrangement can also be further extended to give automatic shutdown on other parameters such as high engine exhaust temperature or high coolant temperature.

A manual start override function is incorporated to enable start before engine oil pressure has built up. This and the manual emergency stop control are both operated via a mechanical cable link to the shutdown valve from a single remotely positioned lever.

The ET Series also include a feature to facilitate the installation of a suitably specified air intake flametrap as a further safety feature.

This range of Wyndham Page automatic engine air intake shutdown valve is suitable for installation on either naturally aspirated or turbocharged engines.

Once installed and set, the repeatability of the actual engine automatic shutdown speed has a greater scatter in the case of turbocharged engines than for naturally aspirated types. However, unless there is a special requirement for a very precise shutdown speed, adequate protection from excessive engine overspeed is achieved.

## Principle of Operation

The actuation force to automatically close the valve on overspeed is derived from the engine intake airflow passing through the valve. As the airflow increases this actuation force also increases. This force is resisted by an internal valve spring, the pre-load of which is adjusted via the “Trip Adjuster Screw”. Once the actuation force exceeds the resisting force of the valve spring, the valve rapidly moves to the closed (engine stop) position.

The ET valve detects low engine oil pressure via an oil pressure input connection to the valve. By installing suitable additional sensors into this oil pressure circuit, automatic valve shutdown on other parameters such as high engine exhaust temperature or high coolant temperature can be achieved. Alternatively a pneumatically operated shutdown control system may be connected to the valve. Additionally the manual stop directly moves the valve to the closed position.

## Description & Main Dimensions

Principal dimensions for this range of Wyndham Page shutdown valves are given in the diagram and tabulated data on page 4.

The valve is supplied complete a hose adaptor at the air inlet selected in consultation with the customer from a range typical for the rating of the engine to be protected. See tabulated information on page 4.

The valve includes a recess into which the customer supplied crimped ribbon type air intake flametrap is to be fitted. Note the intake flametrap must be to a specification approved for diesel engine air intake applications and be designed for a recess depth of either depth 21 or 41mm - see diagram and tabulated data on page 4.

The standard stocked lengths from which the manual shut down / start override cable may be selected are also given on page 5. Alternative cable lengths may be available on application.

The threaded port for connection of the oil (air) pressure signal is marked G1/4 on the diagram on page 4.

METRIC TABLE	ENGINE POWER (KW)		DIMENSIONS (MM)										
MODEL	MIN	MAX	FLAME TRAP H	A	B	L (MAX)	MASS (KG)	STOCK HOSE ADAPTORS C (OTHER SIZES AVAILABLE ON REQUEST)					
E30T20	40	90*	21	130	130	20	3.75	60	70	77	83	89	102
E30T40			41		150		3.9						
E40T20	50	110*	21	144	147	25	4.1	70	77	83	89	102	
E40T40			41		167		4.25						

IMPERIAL TABLE	ENGINE POWER (HP)		DIMENSIONS (INCHES)										
MODEL	MIN	MAX	FLAME TRAP H	A	B	L (MAX)	MASS (LB)	STOCK HOSE ADAPTORS C (OTHER SIZES AVAILABLE ON REQUEST)					
E30T20	54	121*	0.83	5.1	5.1	0.79	8.3	2.4	2.8	3.0	3.3	3.5	4.0
E30T40			1.61		5.9		8.6						
E40T20	67	148*	0.83	5.7	5.8	0.98	9.0	2.8	3.0	3.3	3.5	4.0	
E40T40			1.61		6.6		9.4						

Power values marked \* may be increased under certain restricted circumstances.  
 Contact Wyndham Page or your Wyndham Page supplier for details. Data subject to change.

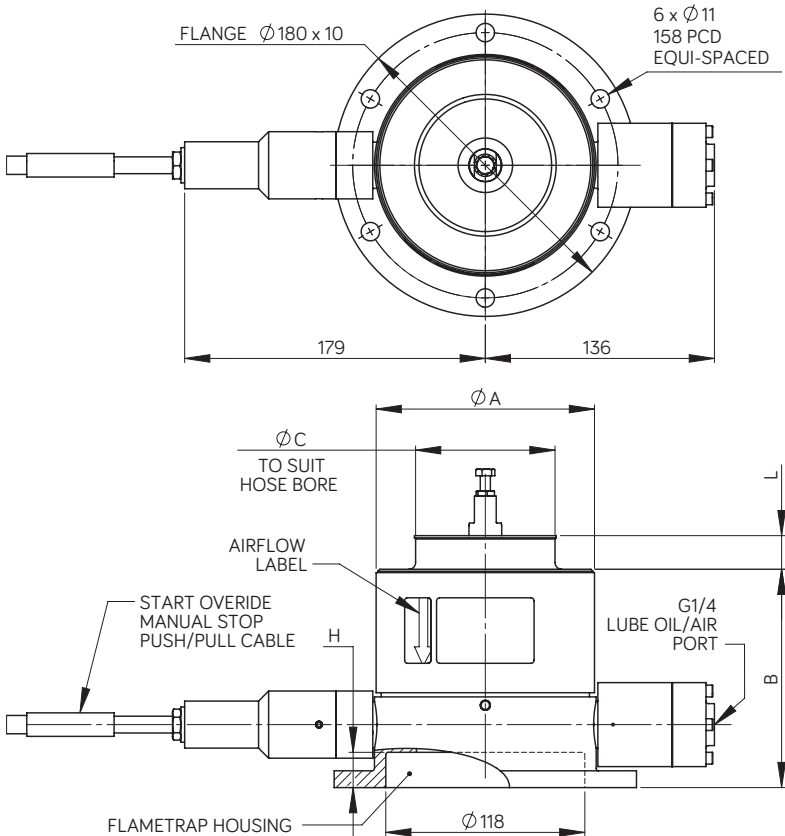

# General Specification

GENERAL DESCRIPTION:	
An air intake shutdown valve with flametrap housing: automatic shutdown on engine overspeed or loss of oil / air pressure, manual shutdown via remote lever.	
GENERAL SPECIFICATION:	
Flametrap:	Suitable for Ø118 x 21 and Ø118 x 41 (flametrap not supplied)
Oil / air pressures:	Minimum oil / air pressure to run approx 1.5 Bar. Valve will start to close when oil / air pressure falls below this value.
	Max oil / air pressure: 10 bar
	Max recommended pressure for shutdown with remote lever: 6 bar
Temperatures:	Max internal and external -40°C to +120°C

## Valve Selection

To enable Wyndham Page to select the most suitable shutdown valve for a given application the following data is required:

- Engine type and model.
- Engine rating and / or application details
- The required depth of the intake flametrap recess
- The internal bore of the intake system hose at the position the valve is to be fitted
- The cable length for the manual shut down / start override

## Order Coding

**EXXTXX - XXX - RXX - S000**

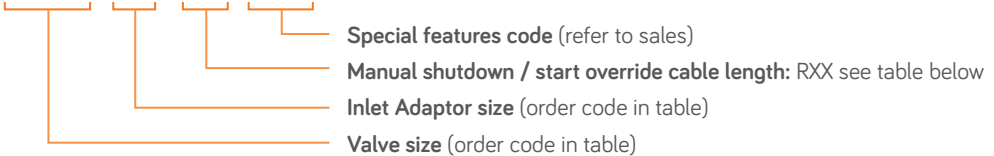

Use metric value for adaptor code, add zero to make 3 digit code e.g. 70 = 070

**Special features:**  
By arrangement with Wyndham Page.

STANDARD CABLE LENGTHS	
CABLE XX CODE	LENGTH (M)
05	0.5
10	1.0
15	1.5
20	2.0
25	2.5
30	3.0

## Valve Installation

Where Wyndham Page ET valves are supplied complete with the manual shutdown / start override lever and cable fitted it is recommended that the lever and cable are not separated from the valve when installing. The lever assembly has three 8.3mm diameter holes for mounting to a bracket or bulkhead (see diagram on page 7).

To reduce shipping size the ET valve may be supplied with the lever / cable assembly removed in which case this must fitted before the valve is installed onto the engine by following the separate procedure in the appendix at the end of this handbook.

Fit the intake flametrap into the recess provided within the shutdown valve assembly and using suitable jointing material, bolt on the customer supplied valve air outlet housing to hold the flametrap in situ.

**Note:** If an intake flametrap is not fitted into the recess provided in the ET valve, but a flametrap is to be fitted elsewhere in the intake system, it must be downstream (engine side) of the ET valve.

Subject to the comments below generally install the Wyndham Page ET valve as close to the engine intake manifold as practical. Always ensure following installation that:

- [a] Adjustment and locking of the setting screw is possible.
- [b] A suitable run for the manual shutdown / start override cable is accommodated and the associated operating lever is positioned to enable easy access for emergency use.
- [c] A suitable run and support for the oil (or air) pressure pipework is provided.

When fitting always ensure the direction of air flow is in compliance with the arrow marked on the body of the valve. The valve may be fitted in any attitude with the air flow between vertically downwards through to horizontal but not in a position where it is subjected to temperatures, internal or external, outside of the range  $-40^{\circ}\text{C}$  to  $+120^{\circ}\text{C}$ .

For turbocharged engines fit the valve upstream of the turbocharger except where a charge cooler is fitted in which case it may be fitted downstream of the charge cooler subject to not exceeding the  $+120^{\circ}\text{C}$  limit. Do not fit valve between the turbocharger and charge cooler.

After installation the intake valve, the intake pipework and any associated support brackets must be adequate to fully support the valve whilst not permitting excessive vibration of the valve. Generally ensure that there is sufficient flexibility in the finalised intake system installation to allow for the relative movement between the system components over the full range of engine operating conditions thereby avoiding excessive mechanical stresses. Long lengths of flexible hose likely to fully collapse when the shutdown valve closes should be avoided.

In the case of an engine with multiple intake systems requiring the fitting of more than one Wyndham Page ET valve, a suitable balance pipe must be installed between the intake system pipes downstream [engine side] of the valves to give simultaneous automatic overspeed shut down of the fitted valves. Typically such a balance pipe should be 30% to 40% of the intake pipe diameter. Also a mechanical linkage is required to ensure that the manual shut down / start override system operates all shut down valves simultaneously.

Any engine crankcase breather arrangement venting directly into the intake ports or into the air intake system downstream of the Wyndham Page ET valve must be sealed and replaced by an external breather system connected to the intake system upstream of the ET valve or [if permitted at the operating site] vented to atmosphere.

**Important note:** Always retain the standard fuel stop provided with the engine. The ET valve manual stop should never be used as the normal way to stop an engine. It is intended for emergency operation only or when checking for correct functioning.

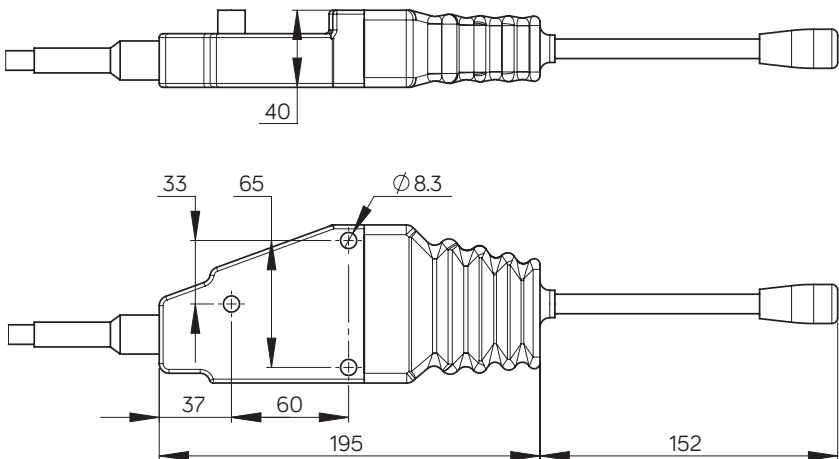

PUSH/PULL CABLE LEVER DETAILS

## Operation

- [1] Carry out all pre-start checks.
- [2] Move the manual emergency stop / start override lever to the start override (engine run) position.
- [3] Continue to hold the lever in the start override (engine run) position whilst carrying out normal engine start procedure.
- [4] When the engine has started the lever must continue to be held in the start override (engine run) position until held in place by the engine oil pressure. This could take up to about 30 seconds.
- [5] To carry out a manual emergency stop move the lever firmly to the stop position.

## Valve Trip Speed Setting

The Wyndham Page ET valve as supplied will normally be set to trip at a speed below that required. To adjust the trip speed use the trip adjuster screw and associated lock nut. See instructions and diagram below.

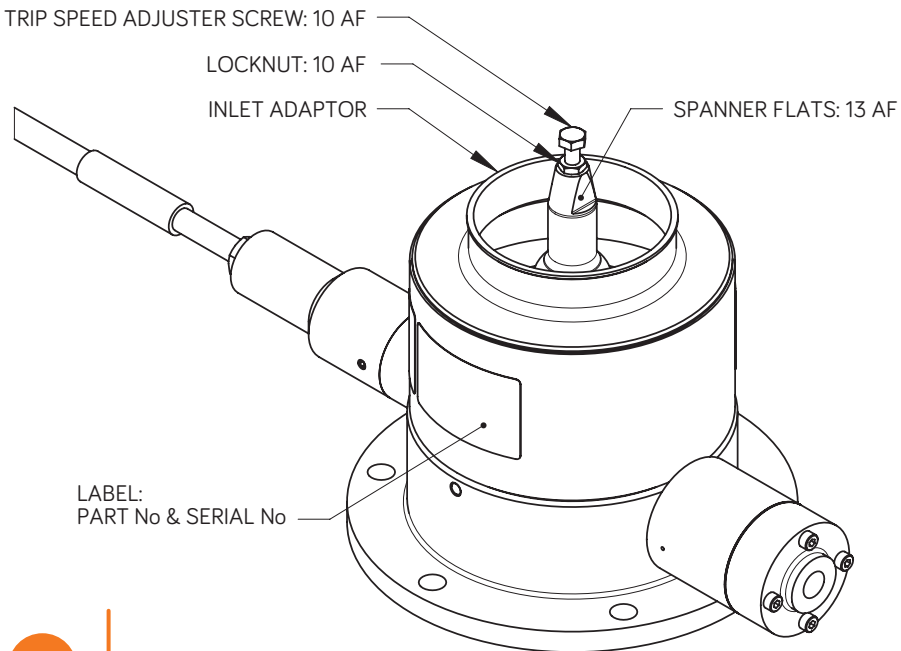



**Rotating the adjuster screw clockwise increases the trip speed. Prior to attempting to set the trip speed check that the manual stop / start override lever is in the engine stop position. To set:**

- [1] Check adjuster screw locknut is tight and that the intake system from air cleaner to intake manifold is fitted and secured and is leak free.
- [2] Start engine. Slowly increase speed until a shutdown occurs. [Note; if no shutdown occurs up to the maximum available engine speed with maximum throttle, remove air hose connection from the inlet end of the Wyndham Page valve to gain access to the setting screw and locknut. Release setting screw locknut and rotate the setting screw two turns anticlockwise. Tighten locknut, refit hose and recheck for shutdown].
- [3] Following initial shutdown remove air hose to gain access to the setting screw and lock nut.
- [4] Release setting screw locknut and rotate setting screw one turn clockwise.
- [5] Tighten locknut, refit air hose, start engine and slowly increase speed up to the maximum available.
- [6] Repeat steps [3], [4] and [5] until the first time that no shut down occurs up to the highest speed available. Then adjust the setting screw a further one half turn clockwise and tighten the locknut. With the intake system fully fitted and the engine fully warmed up slowly run up and down the engine speed range a number of times to check no further shut down occurs. If a further shut down occurs reset the adjuster screw one further half turn clockwise and check again until no shut down occurs.
- [7] Finally restart the engine and run at about half maximum speed [or higher if this not possible]. Operate the manual emergency stop to ensure the engine stops within a few seconds.

**Notes:**

In the case of turbocharged engines it is important that the final checks of item 6 above are carried out with the engine under load.

A more precise method to set the trip speed is achieved by monitoring and recording the engine speed during adjustment and by temporarily raising the engine high idle speed [if safe to do so] to enable the final trip setting speed to be measured. Once the trip speed is set, the high idle must be reset to its standard setting.

## Maintenance

The following maintenance schedule should be undertaken. Subject to experience of local operating conditions the frequency of the maintenance requirements may need to be varied.

- DAILY: Run engine at mid-range speed [or higher if this if this not possible].  
Operate the manual emergency stop. The engine should stop within a few seconds.
- MONTHLY:
- [1] Check intake pipework between the valve and engine to ensure all pipe fixings and any support brackets are properly fitted and secure and that the engine intake is leak free and shows no signs of significant damage.
  - [2] Check that the oil (air) pressure pipe to the valve and any exposed associated automatic shutdown system pipework is suitably supported and free from leakage or visible damage.
  - [3] Check that the manual shut down / start override cable is adequately supported and free from visible damage.
  - [4] Check the shutdown trip speed setting is correct by either:
    - [a] Carrying out the trip speed adjustment as outlined herein or;
    - [b] Temporarily raise the engine high idle and check trip speed using an engine tacho.
- 3 MONTHLY:
- [1] Remove valve complete with the manual stop / start override lever and cable.
  - [2] Clean valve as necessary using a soft brush / airline plus white spirit or similar if necessary taking all normal precautions. Dry valve.
  - [3] Check that the valve moves smoothly over its complete operating stroke and that there are no signs of significant damage or excessive wear. Do not lubricate.
  - [4] Check the manual shutdown / start override cable for damage and wear. Check it operates freely.
  - [5] Refit valve and complete “monthly” checks as above plus daily check where applicable.

NOTES:

- [a] Carry out the above maintenance whilst the engine is in a non-hazardous area.
- [b] Where applicable ensure that the high idle speed of the engine is reset to the correct value.
- [c]. Any problems identified must be rectified before returning the equipment to a hazardous area.

## Appendix: Fitting of Manual Stop / Start Override Cable

### PREPARATION:

- [1] Mount valve securely to work bench
- [2] Attach air supply to G1/4 thread and apply 2.5/3 bar (36/43 psi) to cylinder. Caution: Valve Shaft and Clevis will move across and project from Spring Bush as shown in drawing view 2.
- [3] Support or mount Control Lever housing so the Lever is free to operate during installation and testing.

### INSTALLATION:

Refer to diagrams on page 13; bracketed items refer to ballooned parts in diagrams.

- [4] Screw the M10 Locknut and Washer (31 & 33) to the back of M10 Cable thread.
- [5] Screw the Cable Tube (17) to the back of M10 Cable thread.
- [6] Set the 0.25-28 Locknut (30) to a distance of 5mm from end of the Cable Rod. Then screw the thread into the Clevis (16) up to the locknut by rotating the entire cable assembly. Do not rotate the valve shaft. Tighten the locknut against the back of the Clevis.
- [7] Screw the Cable Tube towards the Clevis (cable must not rotate) until it is approx. 42mm (See View 1) from the Cable Ferrule. Slide the Cable Tube onto the Spring Bush until it stops against the shoulder of the Spring Bush.
- [8] Apply Threadlock (Loctite 243) then fit the 2 Socket Set Screws (27) so that they engage in the groove in the Spring Bush and tighten.
- [9] With the Flametrap removed look inside the valve and check that Cable Grip is oriented so that the internal cable is located at the top of the shaft as shown in the cutaway detail B. If not, rotate the manual stop / override cable to align the internal cable as shown.
- [10] Tighten the Lock Nut (31) and Washer (33) against the back face of the Cable Tube.

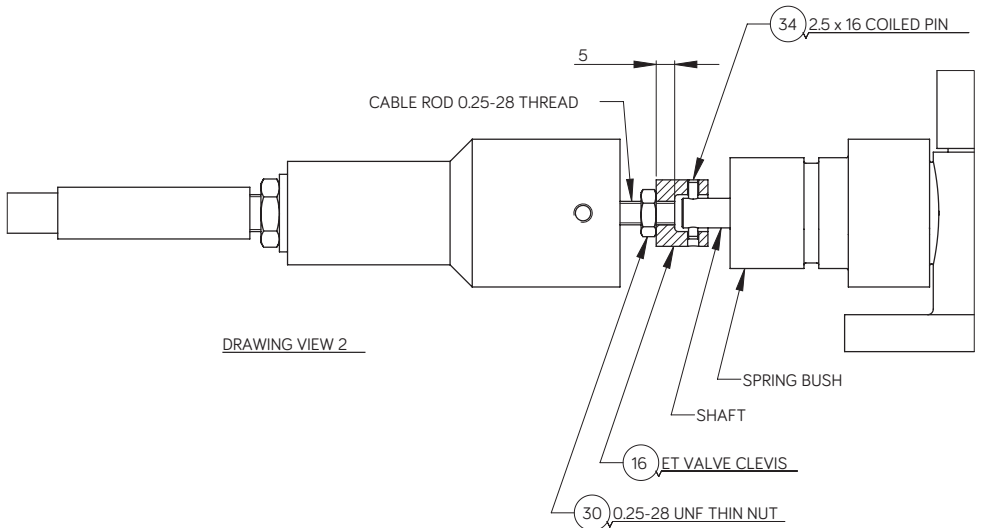
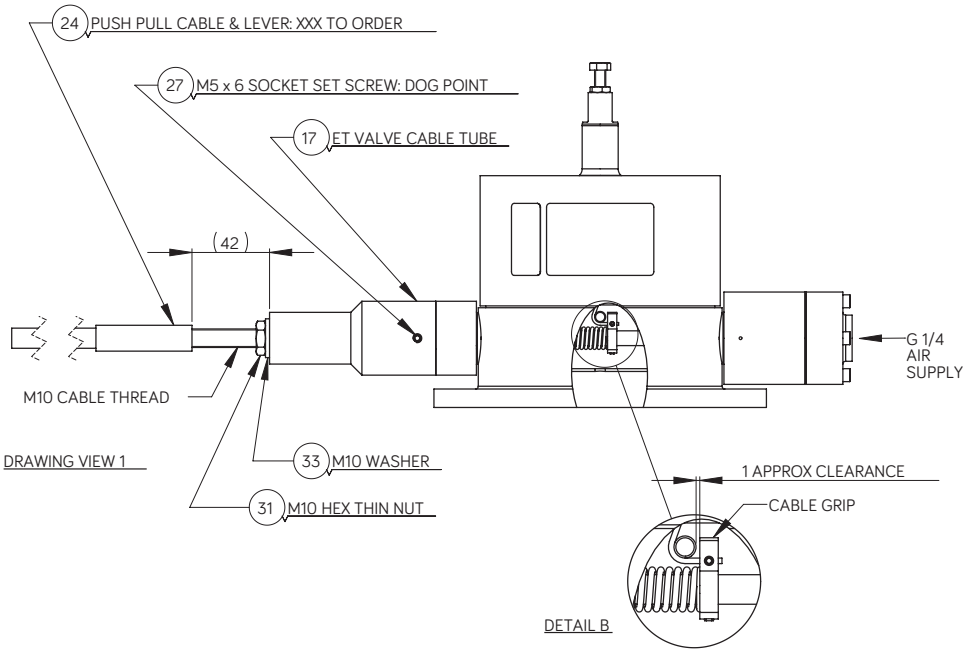

Notes:

Notes:

wyndham | page

Unit 1c Chalwyn Industrial Estate, Parkstone, Poole,  
Dorset BH12 4PE United Kingdom

Tel: +44 (0)1202 734 656

Email: [sales@wyndhampage.com](mailto:sales@wyndhampage.com)

[www.wyndhampage.com](http://www.wyndhampage.com)