

FP2 Valves

Air Pressure to Close / Auto Reset

Part of the F Series of easily installed, compact, air intake valves for diesel engine emergency shut down.

New Speed Switch Kit
available for a complete
overspeed installation

See page 3



About Wyndham Page Ltd

Based in the UK Wyndham Page specialise in the design and manufacture of safety equipment for diesel engines.

Our product range of Air Intake Shutdown Valves includes our E Series Automatic Valves and our F Series Butterfly Valves with solenoid, pneumatic or manual actuation options. We offer Speedswitch kits for the F Series valves and a range of Spark Arresters designed to prevent the emission of high energy sparks from diesel exhaust systems.

Wyndham Page is headed by Freddy Page-Roberts who brings over 20 years' experience in the diesel safety industry and was previously managing director of Chalwyn Ltd.

All members of the senior management team have considerable experience in organisations specialising in the design and manufacture of hazardous area equipment for diesel engines.

Quality Assurance

Wyndham Page Valves are manufactured and tested under our EN ISO 9001: 2015 quality management system.

Wyndham Page Ltd are certified to supply ATEX equipment under Quality assurance Certificate CML ATEXQ11003.

- Equipment supplied with an EC Type Examination Certificate is CE marked and meets the provision of the ATEX directive 2014/34/EU.
- Self-certified equipment supplied with an EU Type Examination Certificate is CE marked and meets the provision of the ATEX directive 2014/34/EU.

FP2 Valves: Application

The FP2 version of the Wyndham Page F Series of shutdown valves is designed to be installed in the air intake system of a diesel engine to provide an emergency means of rapid shutdown.

The FP2 valve is suitable for applications where there is a supply of filtered dry or lubricated air (or inert gas) available from 3 to 8 Bar (43 to 116 psi). This air supply is used to close the FP2 valve thereby bringing the running engine to a stop within a few seconds in an emergency. Venting of the air pressure signal results in the automatic reset of the valve to the open condition. This mode of operation makes the FP2 valve suitable for applications where non-failsafe operation is permitted such as emergency vehicles etc.

A shutdown control system is required to automatically apply the air pressure signal to the FP2 when engine overspeed or any other selected fault condition is sensed.

Important Note: A manual emergency shutdown button should also be incorporated in the shutdown control system.

The low intake air flow restriction through the open valve makes it generally compatible with the requirements of low emission diesel engines.

Corrosion resistant materials are used where applicable in the construction of the valve. This lightweight and compact valve design together with the availability of factory fitted hose adaptors selected from a wide range of optional sizes assists in easy installation.

The valve may be fitted to either turbocharged or naturally aspirated engines. In the case of turbocharged engines temperature limitations may restrict the position in which the valve may be installed in the intake system.

New Speed Switch Kits now available

Wyndham Page also supplies Speed Switches and a range of Installation Kits for incorporation into the emergency shutdown control circuit of this type of application. Details can be found in our **“Speedswitch Kits - FP2 Valve” Handbook** available for download on our website. Please contact Wyndham Page or your Wyndham Page supplier for additional details.

Description and Main Dimensions

In standard form the FP2 valve is available complete with hose adaptors as selected by the customer from a range of standard sizes – see diagram below and data on pages 5 and 6. Where a requirement exists for a non-standard adaptor size or other alternative form of intake pipe connection such as flanged joint, please pass details of requirement to Wyndham Page or your Wyndham Page supplier for investigation.

The valve has a metal to metal seal when closed. It is designed for low closing friction and long life of the sealing surfaces and is designed to withstand high shock loads without malfunction.

The diagram below and the diagrams and data on pages 5 to 6 cover the main features and basic dimensions of the FP2 including selection of options and order coding.

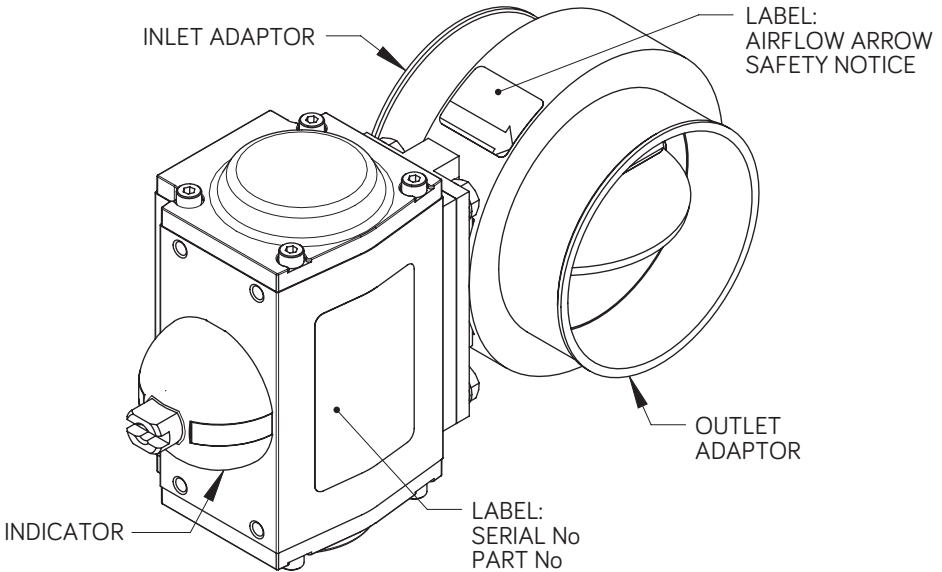

METRIC TABLE		DIMENSIONS (MM)					WEIGHT KG	ORDER CODE
MODEL	H TO SUIT HOSE BORE	BORE A	B	C	D	E		
FP2	38	57	81	196	50	20	1.38	38
	44						1.37	44
	51						1.38	51
	57						1.37	57
	64						1.37	64
	70						1.41	70
	76	71	99	215	28	25	1.31	76S
	83						1.22	76
	89						1.31	83
	95						1.51	89
	102	95	125	241	35	25	1.69	95
	108						1.68	102
	114						1.76	108
	121						1.85	114
	127						2.13	121
	133						2.14	127
	140	120	154	270	42	25	2.24	133
	146						2.37	140
	152						2.69	146
	159						2.94	152
165	145	185	302	49	25	3.08	159	
171						3.21	165	
178						3.35	171	
184	171	215	330	56	30	3.97	178	
203	192	238	351	65	40	5.36	203	

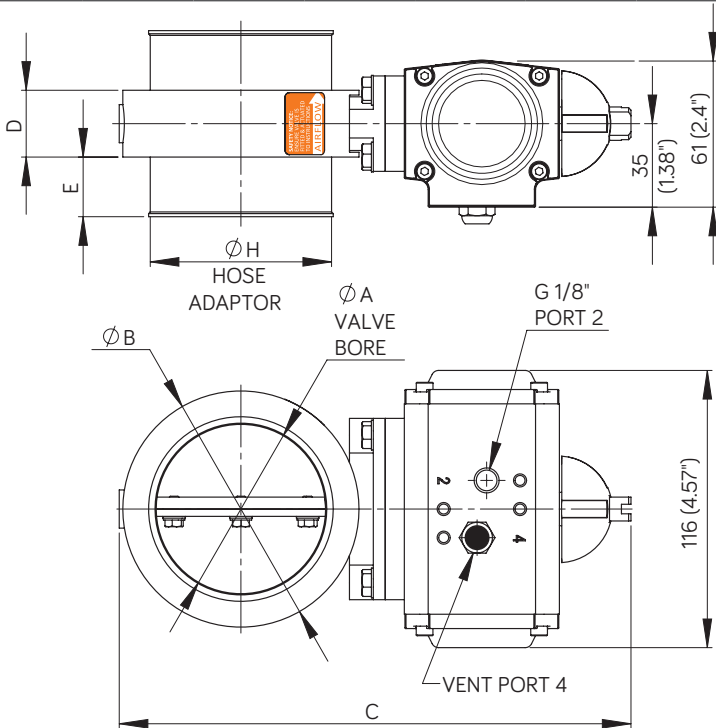

IMPERIAL TABLE		DIMENSIONS (INCHES)					WEIGHT LB	ORDER CODE
MODEL	H TO SUIT HOSE BORE	BORE A	B	C	D	E		
FP2	1.50	2.24	3.19	7.72	1.97	0.79	3.04	38
	1.73						3.02	44
	2.01						3.04	51
	2.24						3.02	57
	2.52						3.02	64
	2.76						3.11	70
	2.76	2.56	3.58	8.15	1.10	0.98	2.89	70S
	2.99	2.80	3.90	8.46	1.10	0.98	2.69	76
	3.27						2.89	83
	3.50						3.33	89
	3.74						3.73	95
	4.02	3.74	4.92	9.49	1.38	0.98	3.70	102
	4.25						3.88	108
	4.49						4.08	114
	4.76						4.70	121
	5.00						4.72	127
	5.24	4.72	6.06	10.63	1.65	0.98	4.94	133
	5.51						5.23	140
	5.75						5.93	146
	5.98						6.48	152
6.26	5.69	7.25	11.84	1.92	0.98	6.79	159	
6.50						7.08	165	
6.73						7.39	171	
7.01						8.75	178	
7.99	7.56	9.37	13.82	2.56	1.57	11.82	203	

Valve Selection

To enable Wyndham Page to select the most suitable version of the FP2 valve for the Customers application the following data is required:

Bore size of the intake hose into which the intake valve is to be fitted - refer to section headed "Description and Main Dimensions".

Order Coding

FP2 - XXX - S000

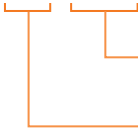

Special features code (refer to sales)
only included in code if required

Adaptor size (order code in table)

Valve Installation

Select a position for the valve which meets the requirements below. The valve may be fitted in any attitude from horizontal to vertical but not in a position where it is subjected to temperatures, internal or external, outside of the range -40°C to $+120^{\circ}\text{C}$. The maximum pressure of the pneumatic signal applied to the FP2 valve is not to exceed 8 Bar (116 psi). When planning and checking installation always ensure that:

- a. There is a suitable run for the connected pneumatic pipework.
- b. The direction of airflow is in compliance with the arrow marked on the body of the valve.
- c. An **Air Filter Element** must always be fitted in the engine air intake system **upstream** of the Valve.
- d. Valve location in the Air Intake System (refer to schematics below):

Yes ✓ No ✗

In all cases the Valve must be located where both ambient and intake air temperature does not exceed 120°C .

- **Normally Aspirated Engines (no turbocharger):** fit the valve between the engine and the air filter (see schematic below).

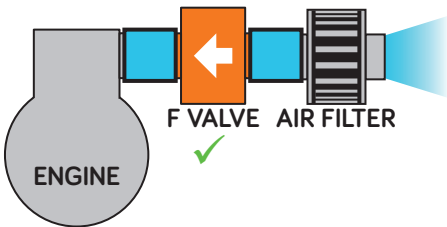

- **Turbocharged Engines:** fit the valve upstream [air filter side] of the turbocharger. **Do not** fit the valve between turbocharger and engine (see schematic below).

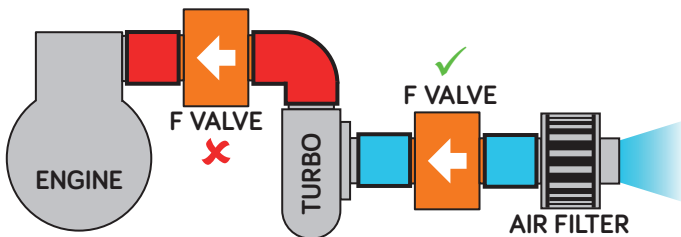

- **Turbocharged Engines with Intercooler:** fit the valve upstream (air filter side) of the turbocharger or downstream of the intercooler. **Do not** fit the valve between turbocharger and intercooler (see schematic below).

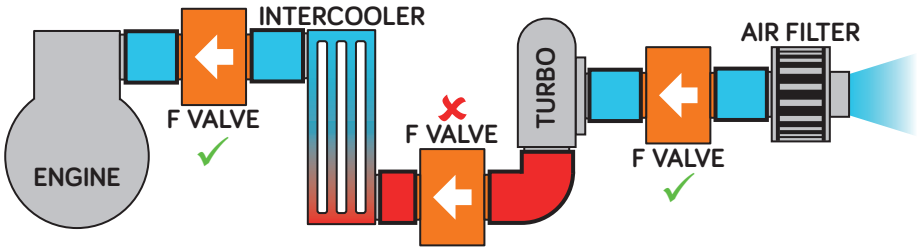

- In all cases where an **Intake Flametrap** is also fitted, the valve must be installed **upstream** of the flametrap.
- The hose into which the valve is fitted should be adequate to fully support the valve whilst not permitting excessive vibration of the valve. For the heavier valves in the range a support bracket for the valve may be necessary. Generally ensure that there is sufficient flexibility in the finalised intake system installation to allow for the relative movement between the system components over the full range of engine operating conditions thereby avoiding excessive mechanical stresses.
- Any engine **Crankcase Breather** arrangement venting directly into the intake ports or into the air intake system downstream of the Wyndham Page valve must be sealed and replaced by an external breather system connected to the intake system upstream of the valve or [if permitted at the operating site] vented to atmosphere.
- In the case of an engine with multiple air intake systems requiring the fitting of more than one FP2 valve, a common pneumatic supply must be used for valve actuation to ensure all intake shutdown valves operate simultaneously.
- The pneumatic pipework must be adequately secured along its length to avoid excessive mechanical stress at the connection to the actuator or any other physical damage under all normal operating conditions and during equipment servicing.

Important Note. Retain the standard fuel shutdown stop fitted to the engine. The Wyndham Page FP2 air intake valve is designed for emergency stop only.

General and Pneumatic Specification

GENERAL DESCRIPTION:	
A slim butterfly valve designed for emergency shut off of the engine air intake.	
Operating Mode: Air pressure to close, Spring to open.	
GENERAL SPECIFICATION:	
Temperature:	Ambient: -40°C to 120°C Max intake air temp: 120°C
Construction:	Body and disk: Hard anodized Aluminium Other main components: Stainless steel, Aluminium Hose adaptors: Aluminium
PNEUMATIC ACTUATOR SPECIFICATION:	
Air Pressure:	Min: 3 Bar (43 psi) Max: 8 Bar (116 psi)
Air Supply:	Filtered Air: ISO 8573 Class 4

Operation

Complete all routine pre-start checks.

Turn on / reset the shutdown control system to enable supply of air pressure to close the FP2 valve if required for emergency stop during engine operation. Note, the available air signal pressure should be continually maintained between 3 and 8 Bar (43 and 116 psi) to ensure the FP2 valve can be closed for engine emergency stop.

Normal engine shutdown should always be via the standard fuel shutdown.

Should the engine standard fuel shutdown fail to stop the engine, operate the manual emergency stop in the shutdown control system to supply the air pressure to close the FP2 valve.

The FP2 valve will automatically reset on removal of the control air pressure signal.

Maintenance

The following maintenance schedule should be undertaken. Subject to experience of local operating conditions the frequency of the maintenance schedule may be varied. Carry out the proposed maintenance work when the equipment is in a safe area and record details of the work carried out. Rectify any problems identified before returning the diesel powered equipment back into service.

FOLLOWING INITIAL INSTALLATION AND THEREAFTER AT WEEKLY INTERVALS:

- [1]. Check all intake pipework between the FP2 valve and engine intake manifold to ensure all pipe fittings and any support brackets are properly fitted and secure and that the engine intake is leak free and shows no sign of significant deterioration or damage.
- [2]. Check out all pipework associated with the shutdown control system for freedom from damage and to ensure all pipe supports are secured and all pipe fittings tight and leak free.
- [3]. Apply the air pressure shutdown control signal to the valve. Check that the valve moves smoothly and quickly from open to closed status. [Note the valve position indicator on the actuator mounted on the valve will confirm valve status].
- [4]. Start engine. Carry out a shutdown using the stop signal from the shutdown control system. Check that the valve snaps shut and brings the engine to a stop within a few seconds.

SIX MONTHLY:

Remove the FP2 valve. Wipe clean as necessary and visually inspect for damage or excessive wear. Bench test valve function. Refit and complete the “Weekly” maintenance as listed above.

Notes:

wyndham | page

Unit 1c Chalwyn Industrial Estate, Parkstone, Poole,
Dorset BH12 4PE United Kingdom

Tel: +44 (0)1202 734 656

Email: sales@wyndhampage.com

www.wyndhampage.com